

Installation and Maintenance Instructions for DAK- sight flow indicators

Table of contents:

- 1,0 Product description and intended purpose (page 2)
- 2,0 Risk and safety references (page 2)
- 3,0 Storage and transport (page 3)
- 4,0 Intended use and material selection (page 3)
- 5,0 Installation and first starting up (page 4)
- 6,0 Maintenance and service (page 5)
- 7,0 Replacement of glass plates (page 6)

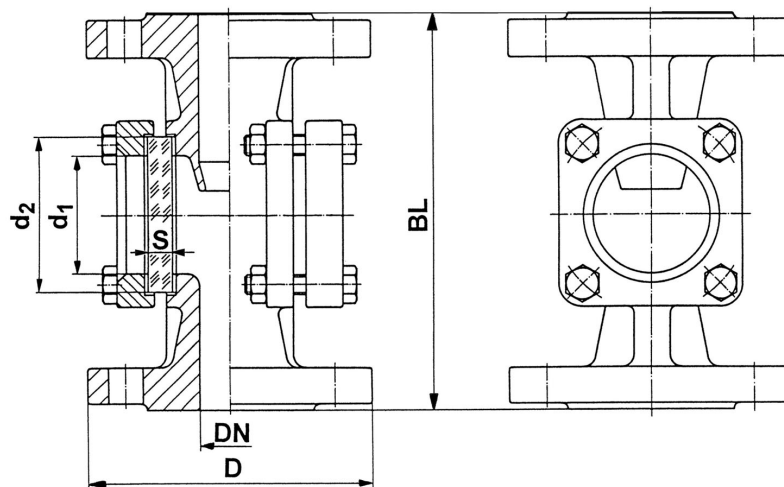

1,0 Product description and intended purpose

DAK- sight flow indicators are built into pipings (flanged, screwed or welded). They serve to make possible the visual inspection of flowing through medium qualitatively and quantitatively for the operator. For this the sight flow indicator is provided with 2 opposite glass plates. For design, dimensions and materials see the corresponding data sheets.

Before leaving our works, all sight flow indicators are examined acc. to DIN 3230 (or corresponding special arrangements) with 1.5 times nominal pressure for strength and with 2 to 6 bar of compressed air under water for thickness.

2,0 Risk and safety references

Very careful dealing with glass plates and sight flow indicators indicators is required:

2,1 It must be guaranteed that all work on or with glass plates and sight flow indicators is done by trained personnel.

2,2 The valid safety regulations, especially for pipings under pressure and temperature, must be considered.

2,3 Before first starting up please follow the instructions mentioned under item 5!

2,4 For cleaning and maintenance please follow the instructions mentioned under item 6 and 7!

2,5 Installation and maintenance must be done exclusively in pressureless and cooled off condition. Shut off reliable supply pipes, in case of back pressure also waste pipes.

2,6 Please use only genuine spare parts.

2,7 **Attention**: During operation, the sight flow indicators may be under pressure and possibly hot! Maintenance during operation means danger of serious burning and cauterization by contact with the process fluid.

2,8 Please wear always safety eye glasses!

3.0 Storage and transport

The sight flow indicators are to be transported and stored in proper packing. They must be kept dry and protected against dirt. Note that the glass plates must be protected against impact and scratching.

Storage: From -10°C to +40°C in a clean and dry room.

Period of storage: Max. 3 years. After that time the seals must be checked and possibly replaced.

Lacquer finish: Cast iron and cast steel sight flow indicators are provided with a basic colour which is to protect the sight flow indicators against corrosion only during transport and storage. Therefore take care not to damage the colour. Condensation must be absolutely avoided.

Protective caps should be removed only shortly before installation.

4.0 Intended use and material selection

Operational area and material selection are subject to the responsibility of the operator and/or designer of the system.

4.1 Body material and seals

These must be selected carefully with consideration of the flowing through medium as well as the operating conditions (pressure and temperature).

4.2 Glass plates

4.2,1 Soda lime glass according to DIN 8902: max. 150°C

4.2,2 Borosilicate glass according to DIN 7080: max. 280°C

4.2,3 Within the very low temperature range there are no limits for the glass plates.

However AD-2000-Instruction W 10 for body and screw materials is to be considered.

4.2,4 Especially for desalinated condensate or steam mixture and pH values starting from 8 an additional protection by mica sheets is recommended.

4.3 Pressure - Temperature – Operational Limits

Operating temperature up to °C	120	150	200	250	280
PN 16 / ANSI 150 lbs	16	15	14	13	11
PN 25	25	23	22	20	17
PN 40 / ANSI 300 lbs	40	37	35	32	28

4.4 Attention:

The lowest value in the combination “body – seals – glass plates” decides the maximum permissible limit for temperature and pressure!

If there is any doubt, please contact the factory.

5.0 Installation and first starting up

- 5,1 Any installation position is possible (except design with flap: installation horizontal or vertical with flow from below upwards).
- 5,2 The casted or hit indication arrow for the flow direction is to be considered absolutely.
- 5,3 Before installation take care that pipings and sight flow indicators are free of dirt.
- 5,4 Transmission of piping tensions on the sight flow indicators due to the installation process is to be avoided
- 5,5 Remove protection caps only shortly before installation to avoid damages of the contact faces.

5,6 Installation

5,6,1 Flange connection

Piping flanges have to be concentrically and parallel. Size of the flange and type of contact faces must fit the sight flow indicators (see DIN 2526). Distance of piping flanges = length of the sight flow indicators plus twice seal thickness. The connection screws must be tightened crosswise, gradually and steadily (see picture in item 7). The torques depend mainly to the used sealing material.

5,6,2 Thread connection

The thread of the sight flow indicator must fit the external thread of the piping in thread type, size and lead. When screwing in, the sight flow indicators must be kept absolutely directly at the screwed end with a suitable fork wrench or pliers. Don't hold at the end of the sight glass covers on no account, because glass break is to be feared.

5,6,3 Welded sight glass fittings

Before welding, the welded ends of the sight flow indicators and pipings are to be cleaned thoroughly and checked whether they fit to each other (diameter, welding chamfer etc.). Welding is to be done only by trained technical personnel with suitable welding methods and welding additives acc. to valid rules of technology. E-welding is to be preferred.

Attetion: Glass plates and seals should be taken off during the welding procedure or should be covered inside and outside to protect them against welding gases and welding splashes. See item 7 (replacement of glass plates)

5,7 First starting up

5,7,1 Before first starting up the torques of the fixing screws of the two cover flanges are to be checked and corrected (especially after a longer intermediate storage!). The torques and procedure described in item 7 (replacement of glass plates) are to be considered!

5,7,2 After the first load with pressure and temperature you can count on a certain “settling” of the seals. Therefore the fixing screws of the covers are to be checked once more in cold and pressureless condition (as described in item 7) and possibly corrected.

6,0 Maintenance and service

6,1 DAK- sight flow indicators do not require any special maintenance.

6,2 If the glass plates should be dirty at the outside, they can be cleaned carefully. The glass surface must not be scratched under any circumstances (stability loss!). Commercial cleaning agents, especially glass cleaning agents, may be used.
Use only clean and soft cloth!

6,3 Inside dirtying of the glass plates may also be cleaned as described before. If the dirt sticks so tight on the glass plates that cleaning as described above is no more successful, the glass plates have to be replaced. Replacement is also necessary if they are corroded by flow or aggressive medium and show an erosive surface (stability loss!). When assembling the cleaned or replaced glass plates, new seals in suitable quality are to be used under all circumstances. See item 7 (replacement of glass plates) and item 2 (safety references).

6,4 General references: Although highly resistant, sight glass plates acc. to DIN 8902 and DIN 7080 are wearing parts with limited lifespan. This depends very much on the specific demand on operation. With rising temperature and rising pH value of the medium the glass erosion increases exponentially. High glass erosion can have a very negative effect on the operational safety. Therefore both glass plates and seals are to be replaced, if there is a recognizable glass erosion. It is advisable to document the specific period of use of the glass plates, so that experience values of the lifespan in concrete case of operation can be collected. That way the punctual and routine replacement of the glass plates can be planned very well.

7,0 Replacement of glass plates

7,1 **Attention**: All work on glass plates has to be done by trained personnel in compliance with the safety instructions mentioned in item 2! Glass plates require very careful treatment!

7,2 Disassembly

7,2,1 Remove the fixing screws of the cover flanges in several steps and crosswise. Remove the cover flanges.

7,2,2 Remove the glass plates as well as the inside and outside seals.

7,2,3 Clean the sealing surface at the body as well as the bearing surface in the cover flange carefully from sealing remainders and check them on damages (scores, wash out, impact spots etc.). Both surfaces must be absolutely clean, flat and without damages!

7,3 New assembly

7,3,1 Lay down the new inside seal (at body side) and the new glass plate of correct size and quality exactly centrally. The seal may not project in the view diameter d_1 . The glass plate has to show a constant gap of approx. 1 to 1.5mm at the complete outside diameter. A contact between glass plate and metal body may not be under any circumstances! This would lead to damage and total breakdown of the glass plate due to different extension coefficients.

7,3,2 Lay down the outside seal (at cover side) and the cover flange exactly centrally on the glass plate. Between glass plate and cover flange the gap of approx. 1 to 1.5 mm mentioned above must also be absolutely guaranteed.

7,3,3 Screw in the fixing screws carefully and thighten them gently by hand. While doing so, all seals and the cover flange may not be shifted! Threads and bearing surfaces of the fixing screws have to be lubricated with temperature resistant thread paste (e.g ANTI-Seize-Paste) before screwing in to avoid seizing of materials and guarantee defined friction values.

7,3,4 Now tighten all screws in several little steps and crosswise (acc. to the opposite picture) with a torque wrench to the torques mentioned in the below chart. All screws must show exactly the same torque to avoid glass tensions.

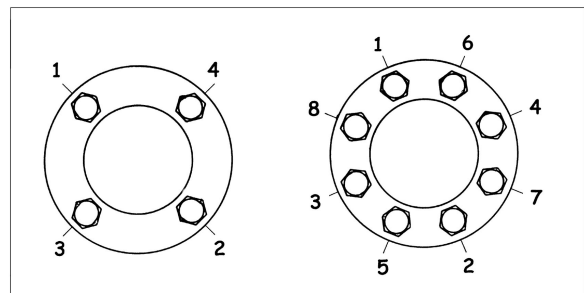

Torques of cover flange screws in [Nm] for lubricated screws and for standard seals made of graphite with stainless steel reinforcement:

Glass Ø d ₂ in mm	View Ø d ₁ in mm	4 x M 8	4 x M 10	4 x M 12	4 x M 14	4 x M 16	8 x M 16
45	32	10	12	--	--	--	--
63	48	12	20	23	--	--	--
80	65	--	23	30	--	40	--
100	80	--	--	42	--	70	35
125	100	--	--	--	65	--	50
150	125	--	--	--	--	100	60
175	150	--	--	--	--	--	80
200	175	--	--	--	--	--	90

Correction values for other sealing materials:

PTFE: above mentioned values x 0.5
 Aramide fibre: above mentioned values x 0.7
 Viton, Silicone, EPDM etc.: above mentioned values x 0.6
 Other materials: on request

7,3,5 Second opposite glass plate side is to be disassembled and assembled again as described above.

7,3,6 Finally the sight glass fitting is to be checked for thickness (e.g. with compressed air/gas of approx. 2 bar under water).

7,3,7 After first restarting the cover flange screws must be controlled absolutely as described in item 5,7,2 in cold and pressureless condition to meet the “settling” of new seals.