



- Measuring range: up to 20 m/s
- Accuracy: $\pm 0.5\%$ of m. v.
- p_{\max} PN 100, t_{\max} 180 °C

- Flange DN 25...1000, DIN/ANSI
- Steel or stainless steel 1.4404
- Analogue, frequency, switching and status output, dosage function



KOBOLD companies worldwide:

ARGENTINA, AUSTRIA, BELGIUM, CANADA, CHILE, CHINA, CZECHIA,
 FRANCE, GERMANY, GREAT BRITAIN, INDIA, INDONESIA, ITALY,
 MALAYSIA, MEXICO, NETHERLANDS, POLAND, SINGAPORE, SLOVAKIA,
 SPAIN, SWITZERLAND, THAILAND, USA, VENEZUELA, VIETNAM

KOBOLD Messring GmbH
 Nordring 22-24
 D-65719 Hofheim/Ts.
 ☎ +49(0)6192 299-0
 Fax +49(0)6192 23398
 E-Mail: info.de@kobold.com
 Internet: www.kobold.com

Model:
 DUL

Description

The DUL ultrasonic flow meter works according to the delay process. This measuring process is based on a simple physical principle. It is comparable with two canoes crossing a river diagonally - one with the current and one against the current. Naturally the canoe that goes with the current reaches the other side faster than the canoe that is going upstream. Acoustic signals behave in a very similar manner.

The lag times of the signals heading upstream and downstream are measured using three pairs of patented ultrasonic measuring sensors. The difference in time lag is proportional to the average flow velocity and is converted into an output signal that serves to display the volume flow-through rate and the total flow-through.

The three measuring paths of the DUL generate a three-dimensional cross-section of the distribution of the flow-through (flow profile) in the material being measured. The measuring paths are positioned such that the effects of changes in the flow profile (laminar or turbulent) are conspicuously reduced. Together with the latest digital signal processing procedure it enables stable and reliable measurement results.

Flow profile

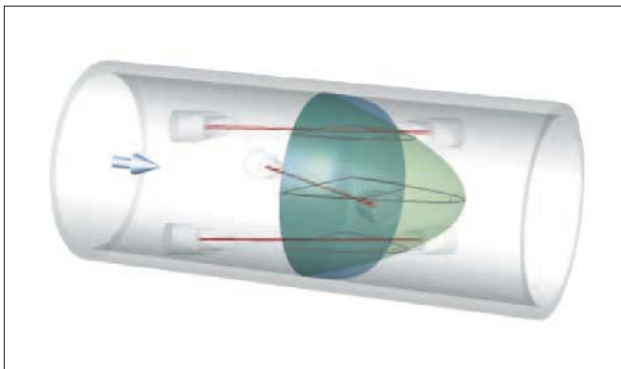

Areas of application

- Fluids and low conductivity solvents
- Cooling water
- Demineralised water
- Low viscosity oils
- Fluids with high pressures and temperatures

Technical data

Measuring range:	0...20 m/s (see table)
Meas. accuracy (under reference conditions):	± 0.5% of measured value (V = 0.5-20 m/s) ± 2.5 mm/s (V < 0.5 m/s)
Repeatability:	± 0.2% of measured value
Medium:	Fluids up to 100 cPs (other media on request)
Max. solids content:	< 5% (volume)
Max. gas content	< 2% (volume)
Installation position:	horizontal and vertical
In/output line:	10 DN / 5 DN
Working temperature:	-25...+140°C (compact version) -25...+180°C (separated version)
Ambient temperature:	-40...+65°C
Max. pressure:	PN 10...PN 100

Materials

Flange:	steel or stainless steel 1.4404
Measuring tube:	stainless steel 1.4404 (DN 25-300) steel (DN 350-1000)
Sensor housing:	steel/stainless steel, polyurethane-coated
Electronics housing:	diecast aluminium, PU polyurethane-coated
Display:	3-line LCD display, backlit, 8 digits + 10 digits + 5 markers
Setting:	via three keys
Languages:	German, English, and French
Functions:	current flow, total volume, V/R flow direction, sound velocity, signal strength, Self-diagnosis, single-stage dosing
Time constants:	0.025-99 s (adjustable)

Leak flow volume suppression

Switching on threshold:	1 - 19% of Q 100%, in 1% steps
Switching off threshold:	2 - 20% of Q 100%, in 1% steps
Current output:	0(4)-20 mA; active/passive
Load:	max. 500 Ω with active switching
Digital output:	pulse, frequency or status output
Pulse output:	pulse/volume, pulse/ time, activ/passive
Status output:	V/R recognition, ceiling, error, dosage volume achieved



Technical data (continued)

Analogue input: 4 - 20 mA
for temperature -50...+150°C
4 - 20 mA
for pressure 0...100 bar (option)

Electrical connection: threaded cable connection M20x1.5
or
thread 1/2 NPT, G 1/2

Signal line: 5 - 30 m (separated version)

Power supply: 100 - 240 V_{AC} (48 - 63 Hz)
or 24 V_{AC/DC}

Power consumption: c. 10 VA (AC); c. 10 W (DC)

Protection: IP 67 or NEMA 6

Electrical connection

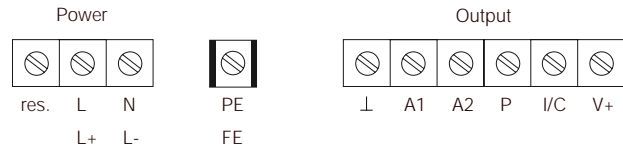

Order details (example: **DUL-1D 25 D A 2 A 0 0**)

Model/ Connection type	Nominal diameter	Pressure level*	Design	Calibration	Cable bushing	Power supply Electronics	Input
DUL-1D = Flange steel DUL-1F = Flange st. steel 1.4404	25 = Nom. diam. DN 25 32 = Nom. diam. DN 32 40 = Nom. diam. DN 40 50 = Nom. diam. DN 50 65 = Nom. diam. DN 65 80 = Nom. diam. DN 80 1H = Nom. diam. DN 100 1Z = Nom. diam. DN 125 1F = Nom. diam. DN 150 2H = Nom. diam. DN 200 2F = Nom. diam. DN 250 3H = Nom. diam. DN 300 3F = Nom. diam. DN 350 4H = Nom. diam. DN 400 4F = Nom. diam. DN 450 5H = Nom. diam. DN 500 6H = Nom. diam. DN 600 7H = Nom. diam. DN 700 8H = Nom. diam. DN 800 9H = Nom. diam. DN 900 1T = Nom. diam. DN 1000	D = PN 100 E = PN 63 F = PN 40 G = PN 25 H = PN 16 I = PN 10 R = ANSI 150lb S = ANSI 300lb	A = Compact version B = Separated version with 5 m cable C = Separated version with 10 m cable D = Separated version with 15 m cable E = Separated version with 20 m cable F = Separated version with 25 m cable G = Separated version with 30 m cable	2 = Standard (2-point) 3 = 3-point 6 = 6-point	A = M20x1.5 with threaded cable connection B = with 1/2 NPT adaptor C = with PF 1/2 adaptor	0 = 100 - 240 V _{AC} 2 = 24 V _{AC/DC}	0 = Standard T = Analogue input for temperature and pressure

*Observe possible pressure levels

Possible pressure levels

Nominal pressure	Material	Nominal diameter																					
		25 / DN 25	32 / DN 32	40 / DN 40	50 / DN 50	65 / DN 65	80 / DN 80	1H / DN 80	1Z / DN 100	1F / DN 125	2H / DN 150	2F / DN 200	3H / DN 250	3F / DN 300	4H / DN 350	4F / DN 400	5H / DN 450	6H / DN 500	7H / DN 600	8H / DN 700	9H / DN 800	11 / DN 1000	
EN 1092-1 - PN 100	St. steel	O	O	O	O	O	*	*	*	*	*	*	*	*	*	*	*	*	*	*	*	*	*
EN 1092-1 - PN 63	St. steel	O	O	O	O	O	*	*	*	*	*	*	*	*	*	*	*	*	*	*	*	*	*
EN 1092-1 - PN 40	St. steel	S	S	S	S	S	O	O	O	O	O	O	O	O	O	O	O	O	O	O	O	O	O
EN 1092-1 - PN 40	Steel	*	*	*	*	*	S	O	O	O	O	O	O	O	O	O	O	O	O	O	O	O	O
EN 1092-1 - PN 25	St. steel	*	*	*	*	*	*	O	O	O	O	O	O	O	O	O	O	O	O	O	O	O	O
EN 1092-1 - PN 25	Steel	*	*	*	*	*	*	O	O	O	O	O	O	O	O	O	O	O	O	O	O	O	O
EN 1092-1 - PN 16	St. steel	*	*	*	*	*	*	O	O	O	O	O	O	O	O	O	O	O	O	O	O	O	O
EN 1092-1 - PN 16	Steel	*	*	*	*	*	*	S	S	S	O	O	O	O	O	O	O	O	O	O	O	O	O
EN 1092-1 - PN 10	St. steel	*	*	*	*	*	*	*	*	*	*	O	O	O	O	O	O	O	O	O	O	O	O
EN 1092-1 - PN 10	Steel	*	*	*	*	*	*	*	*	*	*	S	S	S	S	S	S	S	S	S	S	S	S
ANSI B16.5 - 150 lbs RF			S	S	S	S	S	S	S	S	S	S	S	S	S	S	S	S	S	S	S	S	S
ANSI B16.5 - 300 lbs RF		O	O	O	O	O	O	O	O	O	O	O	O	O	O	O	O	O	O	O	O	O	O

S = Standard; O = Option; * = on request

Dimensions and weights

DN 25 - 300

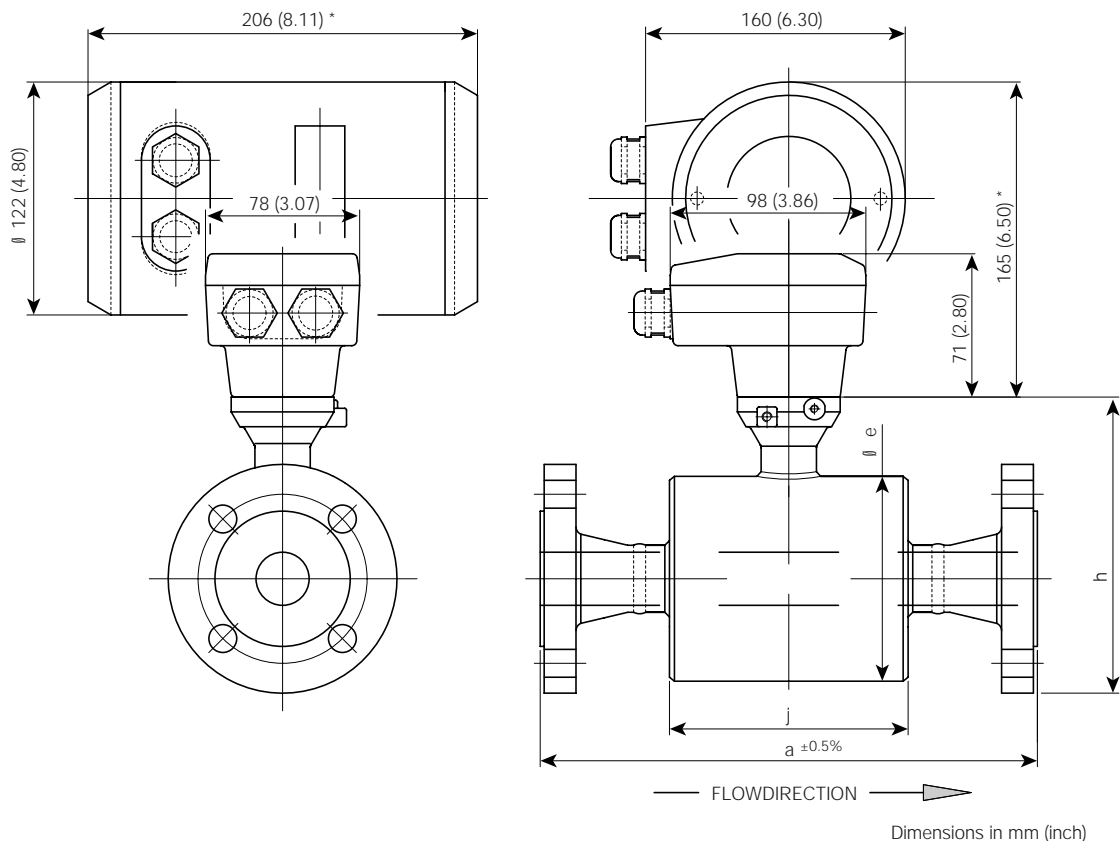



DIN flanges

Nom. diam. DN [mm]	Dimensions in mm				Weight [kg*]
	a	e	h	j	
25	250	106	150	120	6.5
32	260	106	162	120	8.5
40	270	106	167	120	9.5
50	300	133	190	152	12.5
65	300	133	200	152	15.5
80	300	190	239	170	16.5
100	350	215	262	190	18.5
125	350	237	288	210	22.5
150	350	266	320	236	27.5
200	400	359	394	225	50.5
250	400	407	445	260	60.5
300	500	457	495	290	75.5
350	500	n.a.	540	n.a.	68.5
400	600	n.a.	595	n.a.	89.5
500	600	n.a.	697	n.a.	117.5

Inside diameter as per DIN norm

*Approx. weight of the sensor in the separated version.

Compact version: add 1.8 kg (4.0 lbs).

Measuring transducer for the separated version:
3.5 kg (7.7 lbs).

ANSI flanges 150 lbs

Nom. diam. ANSI	Dimensions [mm]				Weight [kg]
	a	e	h	j	
1"	250	106	146	120	6.5
1¼"	260	106	152	120	7.5
1½"	270	106	157	120	8.5
2"	300	133	183	152	12.5
2½"	300	133	196	152	16.5
3"	350	190	234	170	17.5
4"	350	215	266	190	23.5
5"	350	237	290	210	27.5
6"	400	266	317	236	35.5
8"	400	359	395	225	66.5
10"	500	407	451	260	74.5
12"	500	457	514	290	104.5
14"	700	-	554	-	119.5
16"	800	-	612	-	158.5
18"	800	-	656	-	175.5
20"	800	-	713	-	210.5

a	Dimensions [inch]			Weight [lbs]
	e	h	j	
9.84	4.17	5.75	4.72	14.3
10.24	4.17	5.98	4.72	16.5
10.63	4.17	6.18	4.72	18.7
11.81	5.24	7.20	5.98	27.6
11.81	5.24	7.71	5.98	36.4
13.78	7.48	9.21	6.69	38.6
13.78	8.46	10.47	7.48	51.8
13.78	9.33	11.42	8.27	60.6
15.75	10.47	12.48	9.29	78.3
15.75	14.13	15.55	8.86	146.6
19.69	16.02	17.76	10.24	164.2
19.69	17.99	20.24	11.42	230.4
27.56	-	21.81	-	263.5
31.50	-	24.09	-	349.4
31.50	-	25.83	-	386.9
31.50	-	28.07	-	464.1

ANSI flanges 300 lbs

Nom. diam. ANSI	Dimensions [mm]				Weight [kg]
	a	e	h	j	
1"	250	106	155	120	7.5
1¼"	260	106	160	120	8.5
1½"	270	106	170	120	10.5
2"	300	133	189	152	14.5
2½"	350	133	202	152	18.5
3"	350	190	244	170	21.5
4"	400	215	279	190	32.5
5"	400	237	303	210	41.5
6"	450	266	336	236	53.5

a	Dimensions [inch]			Weight [lbs]
	e	h	j	
9.84	4.17	6.10	4.72	16.5
10.24	4.17	6.30	4.72	18.7
10.63	4.17	6.69	4.72	23.1
11.81	5.24	7.44	5.98	32.0
13.78	5.24	7.95	5.98	40.8
13.78	7.48	9.61	6.69	47.4
15.75	8.46	10.98	7.48	71.7
15.75	9.33	11.93	8.27	91.5
17.72	10.47	13.23	9.29	117.9

Dimensions
from DN 350

