



KOBOLD Instruments Inc.  
 1801 Parkway View Drive  
 Pittsburgh, PA 15205  
 PH: 412-788-2830  
 FAX: 412-788-4890  
 www.koboldusa.com

**Series TED**  
**Optical Liquid Level Sensor**

**Precautions**

- **User's Responsibility for Safety:** KOBOLD manufactures a wide range of process sensors and technologies. While each of these technologies are designed to operate in a wide variety of applications, it is the user's responsibility to select a technology that is appropriate for the application, to install it properly, to perform tests of the installed system, and to maintain all components. The failure to do so could result in property damage or serious injury.
- **Proper Installation and Handling:** Use only Teflon pipe tape as the thread sealant in all installations. Never overtighten the sensor within its fittings. Always check for leaks prior to system start-up.
- **Wiring and Electrical:** Because this is an electrically operated device, only properly trained personnel should install and maintain this product. Be sure that the power supplied to the unit is appropriate for the electronics version supplied. Electrical wiring of the sensor should be performed in accordance with all applicable national, state and local codes.
- **Temperature and Pressure:** The TED is designed for use in application temperatures and pressures as listed below. Operation outside these limitations will cause damage to the unit.
- **Material Compatibility:** The TED's process wetted parts for the various body materials are stated below. Make sure that the TED is chemically compatible with the application liquids. While the sensor's outer housing is liquid resistant when installed properly, it is not designed to be immersed. It should be mounted in such a way that it does not normally come into contact with fluid.
- **Flammable, Explosive and Hazardous Applications:** The TED is not an explosion-proof design. It should not be used in applications where an explosion-proof design is required.
- **Make a Fail-Safe System:** Design a fail-safe system that accommodates the possibility of sensor or power failure. In critical applications, KOBOLD recommends the use of redundant backup systems and alarms in addition to the primary system.

**Specifications:**

**Wetted Parts:**  
 Teflon: PFA / PTFE  
 Polysulfone: Polysulfone  
 SS: 303 SS, Viton, Borosilicate Glass

**Max. Pressure @ 70°F:**  
 Teflon: 200 PSIG  
 Polysulfone: 200 PSIG  
 SS: 400 PSIG

**Process Fitting:**  
 Teflon: 3/8" MNPT  
 Polysulfone: 3/8" MNPT  
 SS: 1/2" MNPT

**Temperature Range:** -40°F to +230°F

**Electrical Protection:** NEMA 4

**Power Supply:** 5 - 35 VDC, 33 mA (excluding load)

**Switch Type:** NPN open collector, 300 mA max.

**Electrical Connection:** 18" wire leads, Polyethylene insulation, 1/2" male conduit (PS & SS models)

**Wiring Diagram:**

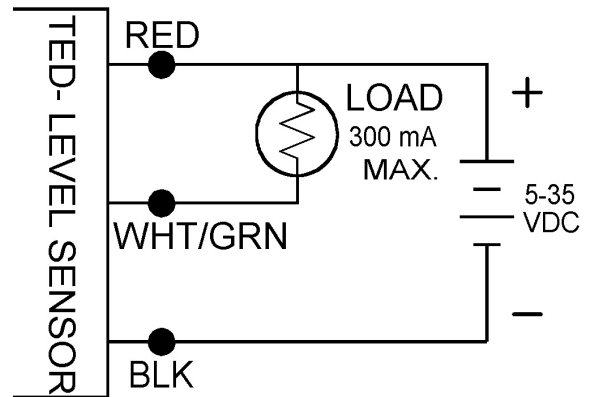

**Installation Torque:**  
 Teflon: 55 in.-lbs. max.  
 Polysulfone: 55 in.-lbs. max.  
 SS: 120 in.-lbs. max.

**Part Number Information**

Material	Model Number
Teflon	<b>TED-3611</b>
Polysulfone	<b>TED-2511F</b>
303 SS	<b>TED-3212A</b>