



Vibrating Level Switches for Bulk Goods



measuring
•
monitoring
•
analysing



- Pressure: max. 25 bar
- Temperature: max. 160 °C
- Connection: 1½ G or NPT
- Material: stainless steel
- Easy to install
- Suited for universal use
- For density > 0.05 kg/dm³
- Self-cleaning



N1

KOBOLD companies worldwide:

ARGENTINA, AUSTRIA, BELGIUM, CANADA, CHILE, CHINA, COLOMBIA, CZECHIA, FRANCE, GERMANY, GREAT BRITAIN, INDIA, IRAN, INDONESIA, ITALY, MALAYSIA, MEXICO, NETHERLANDS, PERU, POLAND, SINGAPORE, SLOVAKIA, SPAIN, SWITZERLAND, THAILAND, USA, VENEZUELA, VIETNAM

KOBOLD Messring GmbH
Nordring 22-24
D-65719 Hofheim/Ts.
☎ +49(0)6192 299-0
Fax +49(0)6192 23398
E-Mail: info.de@kobold.com
Internet: www.kobold.com

Model:
NVI

Description

The KOBOLD NVI level switch is a mechanical system that is made to resonate by an electronic switching operation. When the probe is covered by a medium, the vibrations are damped. This change in the resonance frequency is converted to a switching signal by electronic means.

Applications

The combined vibrating switch can be used in powdery media and granular materials. The medium to be measured should have a density of at least 0.05 kg/dm³. The single rod design prevents deposit formation. The rod is self-cleaning, as the vibrations shake off the medium.

The combined vibrating switch is in successful service in the following applications:

- Plastics industry: powders and granular material
- Chemical industry: powders, pellets and crystals
- Foodstuffs: grain, maize, flour, animal feed
- Paper making: cellulose, wood chips
- Recycling: plastic granules, paper shavings
- Power stations: flue dust, lime, coal
- Stones and earth: coal, stone powder
- Building and construction industry: cement, sand, lime

Selection criteria

The system is set at the factory for a medium density of 0.3 kg/dm³. When the medium has a low density, the sensitivity can be set to this density with a DIP switch. The level switch is inserted in the medium to be monitored for this purpose.

Technical Details

- Special lengths: 235 mm
extended version upon request
- Process connection: G 1½ or 1½ NPT
- Material for wetted parts: 1.4571 (AISI316Ti)
- Sensor surface: bright
- Medium temperature: -30°C...+110°C standard
-30°C...+160°C high-temperature
- Ambient temperature: -40°C...+60°C
- Maximum pressure: 25 bar
- Minimum density of medium: 0.05 kg/dm³
- Max. grain size: 10 mm
- Max. sensor capacity: (depending on the density of solids)
vertical: 445 N
horizontal: 85 N
- Response time: < 1.8 s or 5 ± 1.5 s
with covered electrode
< 2 s or 5 ± 1.5 s
with non covered electrode
- Output: changeover contact 250 V_{AC}/8 A
- Power supply: 85...265 V_{AC}; ≤ 2.5 VA; 1.2 W
120...375 V_{DC}; ≤ 2.5 VA; 1.2 W
16...40 V_{AC}; ≤ 2.5 VA; 1.3 W
19...55 V_{DC}; ≤ 2.5 VA; 1.3 W
- Electrical connection: M20x1.5
- Protection: IP 67
- Weight: 2.5 kg

Dimensions

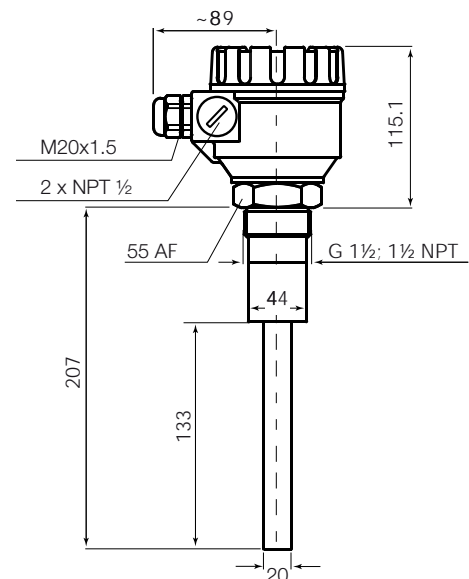

Order Details (Example: NVI-1 300 R)

Model	Version	Power supply	Connection
NVI-	1 = standard	300 = 85...265 V _{AC} 120...375 V _{DC}	R = G 1½ N = 1½ NPT
	2 = high temperature	302 = 16...40 V _{AC} 19...55 V _{DC}	