

**Operating Instructions
for
Level Control Relay Module
Model: MSR**

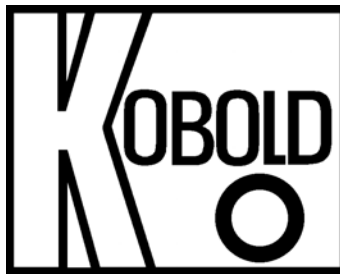

MSR Level Control Relay Module

1. Note

Please read and take note of these operating instructions before unpacking and commissioning. The instruments may only be used, maintained and installed by qualified personnel familiar with the operating instructions and the applicable health and safety requirements.

2. Contents

1. Note
2. Contents
3. Specific Application
4. Operating Principles
5. Instrument Inspection
6. Mechanical Installation
7. Technical Specifications
8. Electrical Connections
9. Start-Up
10. Troubleshooting
11. Maintenance

3. Specific Application

The Level Control Module has been designed for use in level monitoring applications and pump control for liquids.

The module consists of a transformer, control logic circuit and output relay.

Type MSR 1122 is a bi-stable latching type control module with SPDT relay contact output. Inputs should be dry (potential free) contacts, for example, reed switch from float type level detector. The module generates 24 VDC to detect input switch closure, the current is limited to 20 mA on the inputs, in order to protect the level switches. In addition the module has built in time delay on the inputs which avoids false triggering due to switch bounce or nuisance tripping from process vibration, waves or bubbles.

4. Operating Principles

The module is designed to provide detection of two levels in a process tank and to control the tank level in either a pump-up or pump-down mode of operation. This module can also be used as a contact isolation relay to isolate low current, pilot duty contacts from high current loads.

Pump-Up Mode

In a pump-up mode, the relay will initiate by switching on the pump when the fluid level in the tank falls below the lower tank level switch. The relay will remain energized (latched) and the pump will continue to operate until fluid fills the tank up to the high level switch. When the fluid reaches the high level switch the control module relay will de-energize and shut off the pump. The control module relay will remain de-energized until the fluid falls below the low tank level switch.

Pump-Down Mode

In a pump-down mode, the relay will initiate by switching on the pump when the fluid level in the tank reaches the upper tank level switch. The relay will remain energized (latched) and the pump will continue to operate until fluid in the tank empties down to the low level switch. When the fluid falls below the low level switch the control module relay will de-energize and shut off the pump. The control module relay will remain de-energized until the fluid level reaches high tank level switch.

MSR Level Control Relay Module

Contact Isolation Mode

In the contact isolation mode, the relay will mimic the function of a contact wired between input pins 12 and 13. If this contact closes, the relay will switch-over and continuity will exist between relay output pins 42 and 43. If this contact opens, the relay will switch back and continuity will exist between relay output pins 42 and 41.

5. Instrument Inspection

The instruments are thoroughly inspected by the factory prior to shipment, and sent in perfect condition. Should any damage to the device be visible, we recommend a thorough inspection of the delivery packing. In case of damage please inform your parcel service/forwarding agent immediately, since they are responsible for damages incurred during transit.

Scope of delivery:

- Level Control Relay Module
- Operation Manual

6. Mechanical Installation

The relay module enclosure is rated IP 20 (approx. equivalent to NEMA 1) which is intended to be used in a dry, dust-free environment. If the relay module will be located in harsh, wet or dusty environments, the user should mount the module in an appropriate enclosure to protect the device.

The relay module is mounted on to an electrical panel using standard 35mm DIN mounting rail, according to DIN 50022. The device snaps on to the DIN rail, and can be removed from the rail by releasing the spring loaded clip, located on the bottom of the device.

MSR Mechanical Drawing Pending

MSR Level Control Relay Module

7. Technical Specifications

Preliminary Technical Data Sheet

Instrument type		Electromechanical Contact Protection Relay
Model		MSR-1122
Housing size	mm	75 x 50 x 100
Housing material		Polyamid 6.6
Supply Voltage		Model number suffix PO3 =115 VAC \pm 10%, 50 – 60 Hz Model number suffix PO4 =230 VAC \pm 10%, 50 – 60 Hz
Power Consumption		5 VA (typical)
Control Voltage		24 VDC
Control Current		20 mA
Input Impedance		3300 Ohm, 100 nF \pm 20%
Maximum Contact "ON" Impedance		4700 Ohm, 47 nF at inputs
Delay Period (initiating)		10 ms
Delay Period (dropping)		20 ms
Output		1 SPDT relay contact
Permissible Load		250 VAC / 8 A resistive / 1840 VA
Temperature Range		-20°C to 60°C
Type of Protection		IP 20/NEMA 1

Specifications subject to change.

MSR Level Control Relay Module

Electrical Connection

ATTENTION! Ensure that the voltage levels of your supply system are in agreement with the voltage levels given on the type label of the device.

- Make sure that the electric supply lines are not active during connection to this device.
- Improper wiring can lead to damage of this device as well as injury to the user.
- Make sure that installation, wiring, and circuit protection are **in accordance with all local electrical codes**.
- Make sure the supply circuit **provides adequate fuse or circuit breaker protection** that is in accordance with the circuit's current rating.
- Make sure that a **motor contactor relay or starter is used to energize the pump circuit, if the pump's current rating exceeds the MSR Level Control's relay rating**.

Wiring Table

Terminal #	Description	Function
A1	Line Power Connection	Connect to 115 VAC supply
A2	Line Neutral Connection	Connect to Mains Neutral Supply
12	Sensor input common	Connect to one side of switches
13	START Input	Momentary Closure of 12 and 13 Energizes Output Relay (Latched)
11	STOP Input	Momentary Closure of 12 and 11 De-Energizes Output Relay (Reset)

With the MSR-010 (non-latching type), terminal 11 is omitted

***Note: To operate the relay in contact isolation mode, jumper pins 12 to 11 and connect control contact to pins 12 and 13**

42	Relay Output Common	
41	Relay Output N/C	Normally Closed Contact When relay energized: 42 and 41 Open
43	Relay Output N/O	Normally Open Contact When relay energized: 42 and 43 Close
82 & 81	24 VDC Excitation	Sensor supply (Maximum 20 mA!)

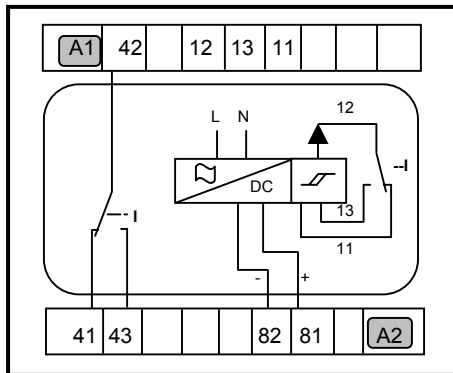

MSR Level Control Relay Module

START & STOP:
Hi and Low Level Contacts
Located on Tank

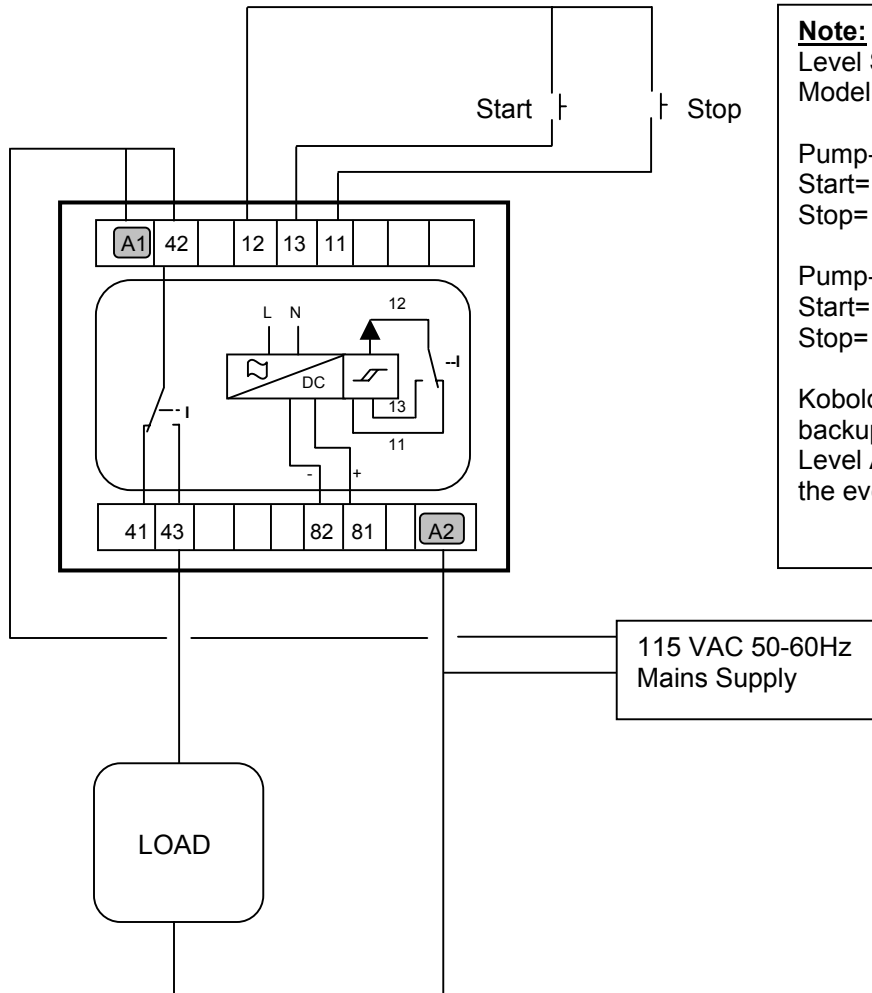

Note: When using Kobold Multi-Point Level Switches Model NCG and NCM

Pump-Up (tank-fill) Application:
Start= Bottom Position N/C (Dry)
Stop= Top Position N/O (Dry)

Pump-Down (tank-drain) Application:
Start= Top Position N/O (Dry)
Stop= Bottom Position N/C (Dry)

Kobold recommends including backup safety switches, example Hi Level Alarm for overflow protection, in the event of pump or circuit failure.

Wiring Diagram for Pump Control*

*Suggested typical setup
Subject to customers final verification & approval
All Specifications subject to change

MSR Level Control Relay Module

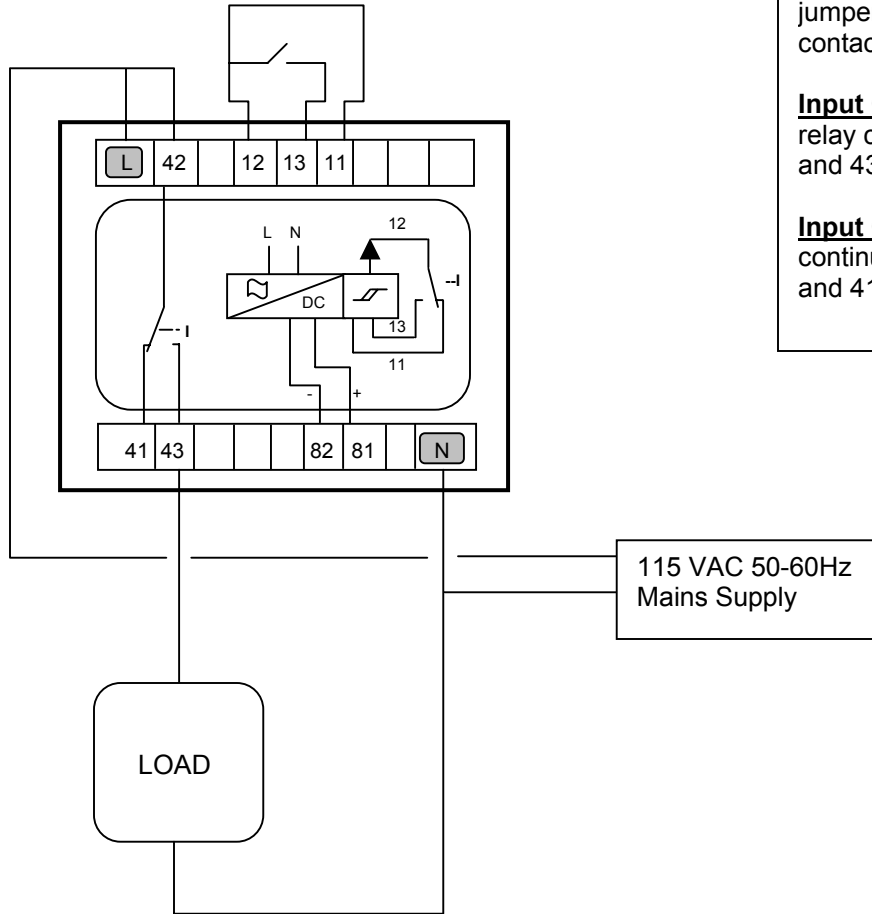

Note: For contact isolation mode, jumper pins 11 and 12. Wire input contact to pins 12 and 13.

Input Contact Closed: Output relay continuity between pins 42 and 43.

Input Contact Open: Output relay continuity exists between pins 42 and 41.

Wiring Diagram for Contact Isolation

*Suggested typical setup
Subject to customer's final verification & approval
All Specifications subject to change

MSR Level Control Relay Module

8. Start-Up

Ensure that all wiring to the Level Control Relay Module is correctly installed, and the level switches are installed and functioning correctly. The Relay Module is now ready for operation, and the supply power to the level control circuit can be applied. Depending on whether the module is wired for pump-up or pump-down mode of operation, the relay should operate in accordance with the description in section 4 - Operating Principles.

9. Troubleshooting

The relay does not operate:

- Check that supply voltage is applied to the L (A1) and N (A2) terminals on the module.
- Check for 24 VDC across terminals 82 and 81. If supply voltage is applied and 24 VDC is not measured across 82 and 81, the module may be faulty.
- Check level switch operation and cabling from the tank location to the module. Temporarily remove the switch inputs from the module and simulate level switch closure by using jumper wires across input terminals.
- When simulating level switch closures the relay does not activate, the relay may be faulty.
- If the relay activates, but does not start the pump, the output wiring or pump circuit may be faulty.

10. Maintenance

The Level Control Relay Module requires absolutely no maintenance. Depending on the type of level sensors used and the process conditions, maintenance to the sensors may be required. Verify and follow maintenance procedures according to the sensor maintenance manual. Verify and follow maintenance procedures according to the pump manufacturer's maintenance manual.

There are no user serviceable parts inside the Type MSR module. If repair is required please contact your local Kobold sales office to arrange a return for repair.

Kobold Instruments Inc.

1801 Parkway View Drive
Pittsburgh, PA 15205
TEL: 412-788-2830
FAX: 412-788-4890
www.koboldusa.com